



Absolute Excellence

Service Bulletin - Piston Rings:



Piston ring failure diagnosis - foreign particle contamination:



Note: oil ring lands worn away on right hand piston.

Appearance:

Running surface worn, Ring flanks scored
Ring grooves badly worn
Liner surface scored

Cause:

Solid particles / debris in engine.
Insufficient cleaning of liner surface after honing.

Symptoms:

Oil consumption, oil smoke from stack
Scoring marks on liner surface
Blow - by

Remedy:

Thorough cleaning of liner surface after honing,
Check oil maintenance system / filters,
Clean engine lubrication system before refilling with new oil.



Absolute Excellence

Service Bulletin - Piston Rings:



Piston ring failure diagnosis - incorrect bore finish:

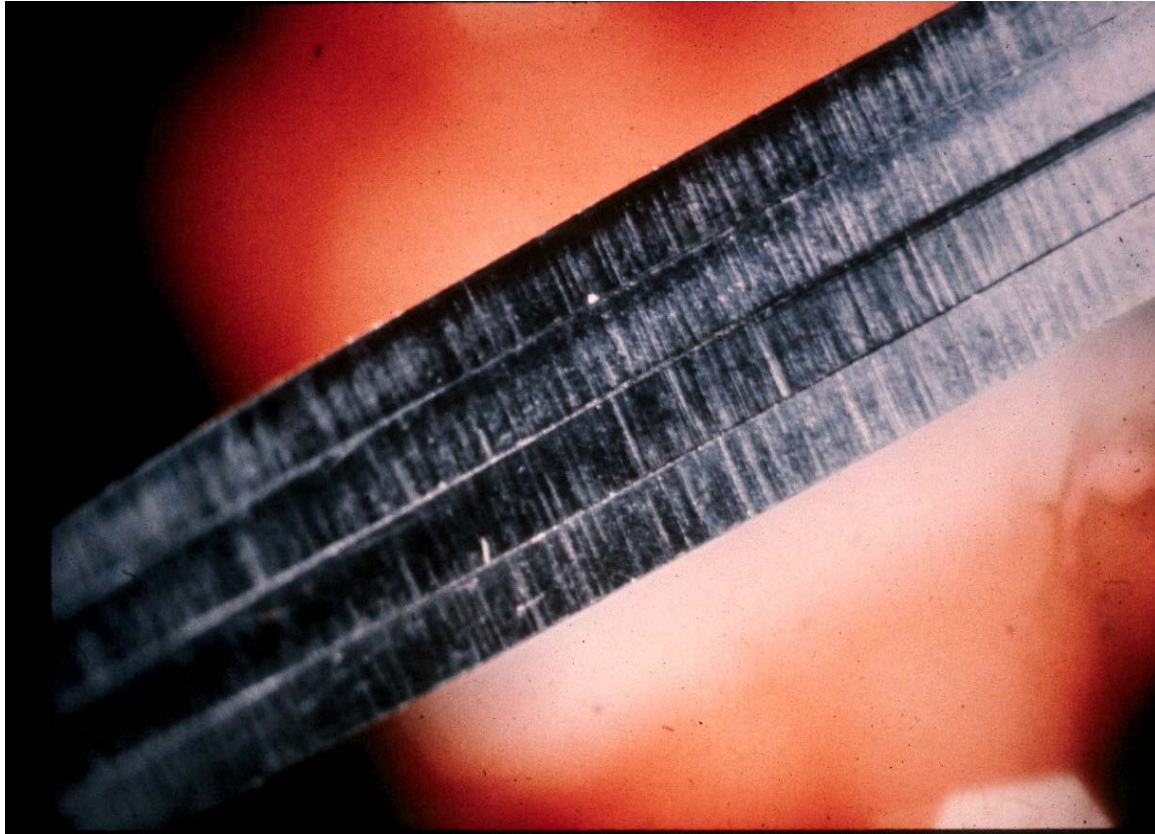

Appearance:

Running surface of rings scored & torn

Cause:

Bore surface finish too coarse.

Honing angle incorrect.

Symptoms:

Oil consumption, smoke from exhaust

Scoring marks on liner surface

Blow - by

Remedy:

Check boring equipment & specifications for correct bore surface finish.

Check oil maintenance system / filters,

Clean engine lubrication system before refilling with new oil.



Absolute Excellence

Service Bulletin - Piston Rings:



Piston ring failure diagnosis - scuffing:



Appearance:

Running surface scuffed, worn

Causes:

Lack of lubrication,

Dry start of engine after ring installation,

Glaze on liner surface

Liner roundness fault

Symptoms:

Oil consumption,

Oil smoke from exhaust

Scuffing marks on liner surface

Blow - by

Remedy:

Correct reconditioning of liner surface,
oil-wettening of liner and rings before
assembly

Control engine lubrication system.



Absolute Excellence

Service Bulletin - Piston Rings:



Piston ring failure diagnosis - high oil consumption:



Appearance:

Oil sludge deposits on scraper edges

Cause:

Engine oil overaged,
Oil contamination with water

Symptoms:

Oil consumption,
Oil smoke from exhaust

Remedy:

Check engine lubrication system,
Check cooling system for leaks.
Clean engine lubrication system before
refilling with new oil.



Absolute Excellence

Service Bulletin - Piston Rings:



Piston ring failure diagnosis - ring/groove side face wear:

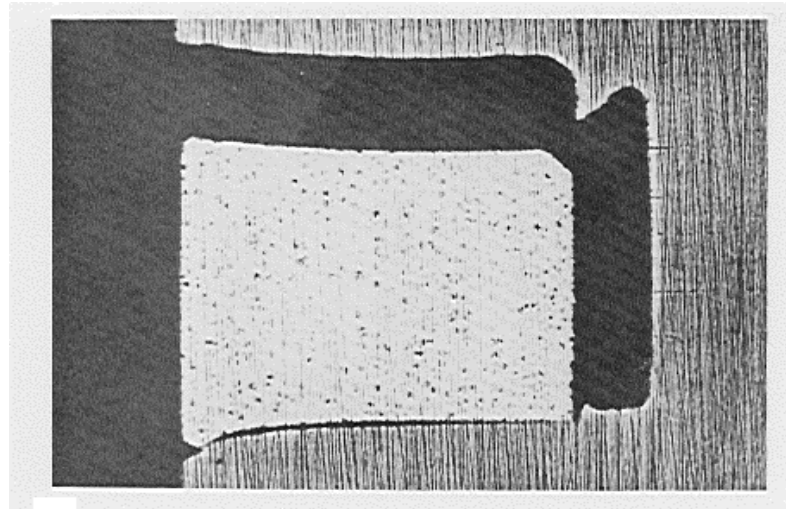
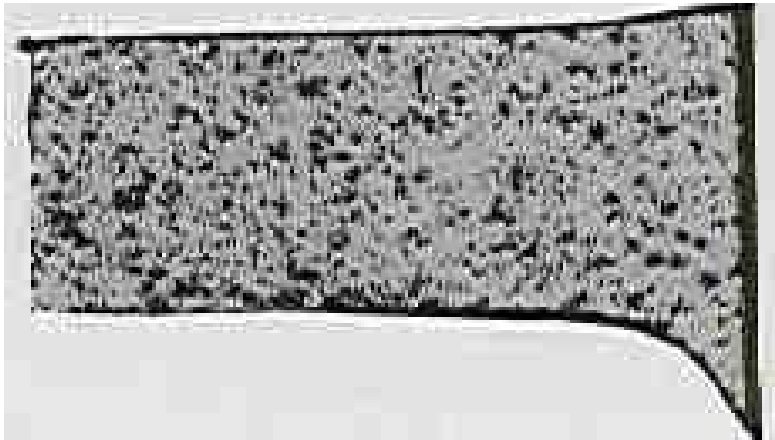

Appearance:

Accelerated wear on side faces of rings (worse on lower side) and ring grooves (compression rings in particular). Other rings may be affected to a lesser degree.

Cause:

Liquid fuel degrading lubricant in ring grooves.

Solid residue from honing erodes flank material.

Symptom:

Oil consumption. Loss of power.

Remedy:

Ensure that fuel mixture is correct, that the choke is not abused or sticking, manifold raw fuel drain is clear, air filter is not blocked or choked.



Absolute Excellence

Service Bulletin - Piston Rings:



Piston ring failure diagnosis - cracked rings:

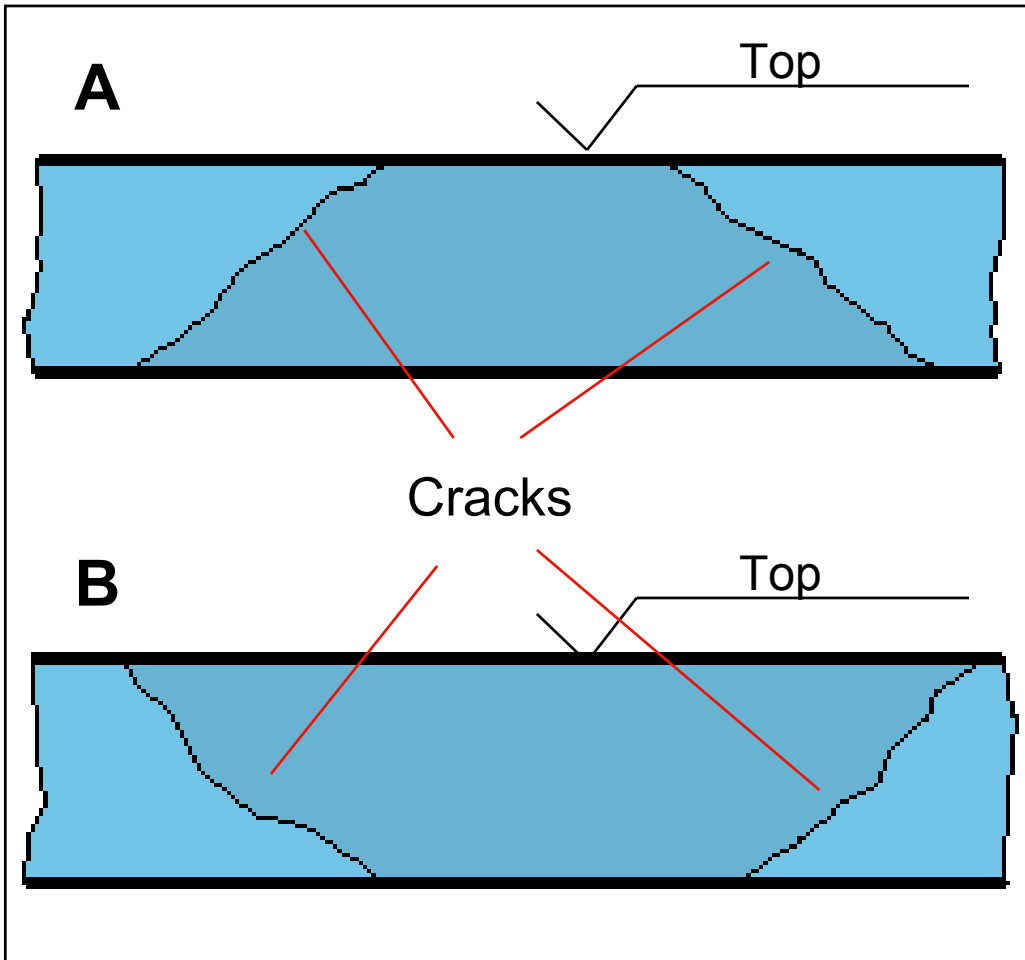

Appearance:

Ring fracture

Cause:

Excessive gas pressure.

Worn-out ring groove.

Installation fault.

Symptoms:

Oil consumption, loss of power

Oil smoke from exhaust

Remedy:

Check engine combustion.

Check ring grooves in piston

Use piston ring expander tool to prevent over-stressing rings during installation.

Remove ridge on upper edge of cylinder before inserting piston.



Absolute Excellence

Service Bulletin - Piston Rings:



Piston ring failure diagnosis - wear limits:

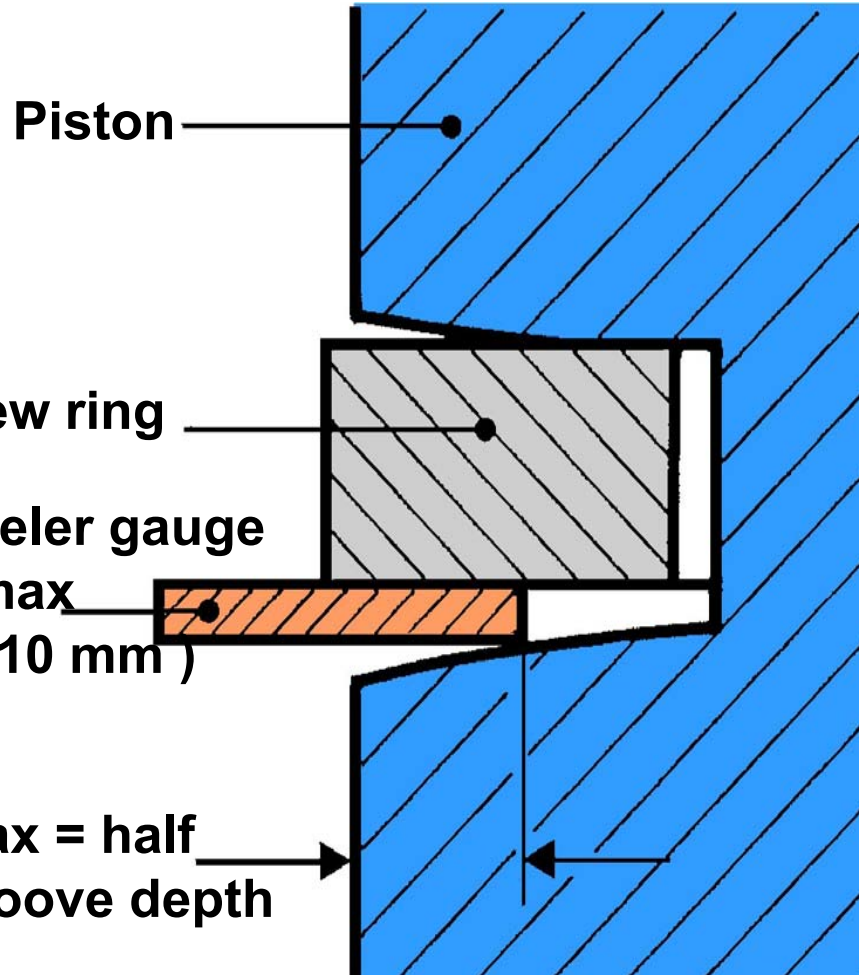

Parallel rings/grooves

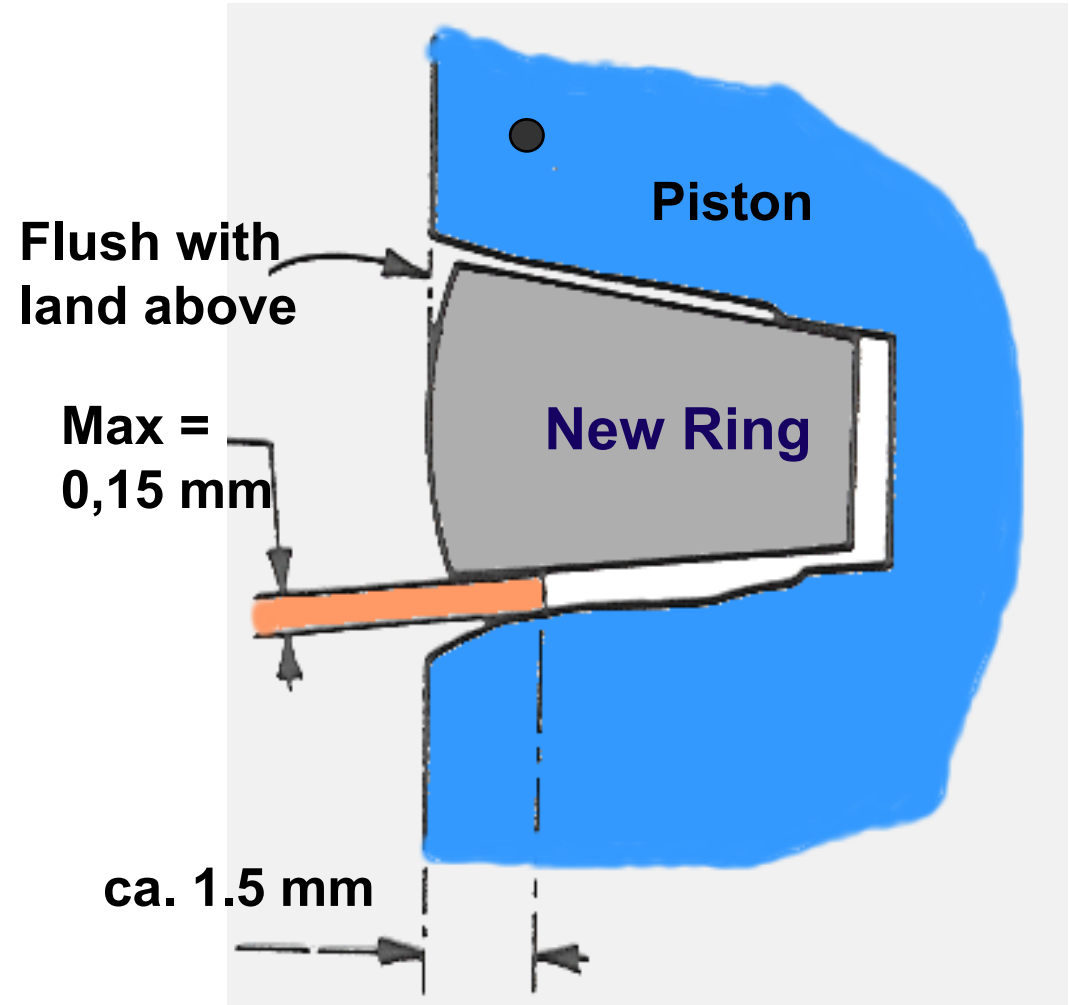

Keystone rings/grooves